

# Tech Guide

## LT TOP MOUNT TVS2650 SUPERCHARGER



Harrop Engineering develops and manufactures premium supercharger systems in Melbourne, Australia and Dayton, Ohio USA. Through almost 70 years of automotive performance Engineering, Harrop have successfully manufactured and supplied Superchargers to Automotive OEM programmes including TRD, Lotus Cars and Ford Australia. Harrop Engineering is certified to meet ISO 9001 quality standards. OEM quality level, performance and vehicle integration are the foundation features of Harrop Supercharger kits.



ENGINEERING PERFORMANCE SINCE 1955

25/11/2024

# Tech Guide

## LT TOP MOUNT TVS2650 SUPERCHARGER



### Key Features:

- High efficiency TVS2650 supercharger
- Drilled for LT1 and LT4 cylinder heads
- Bypass valve integrated for increased efficiency at low engine loads
- Twin dual pass intercooler cores
- 17mm inlet and outlet on each intercooler
- 2.7 bar MAP sensor GM 12592525
- IAT sensor GM 25037388
- 1/8" BSPT boost referenced ports
- Retains OEM direct injection functionality
- Optional port injection kit
- Pulley options to suit L87, L8T and LT4 engines
- Choice of 5 different front covers to suit various airbox and throttle needs
- Manifold assembly part number 99-AMFD14272

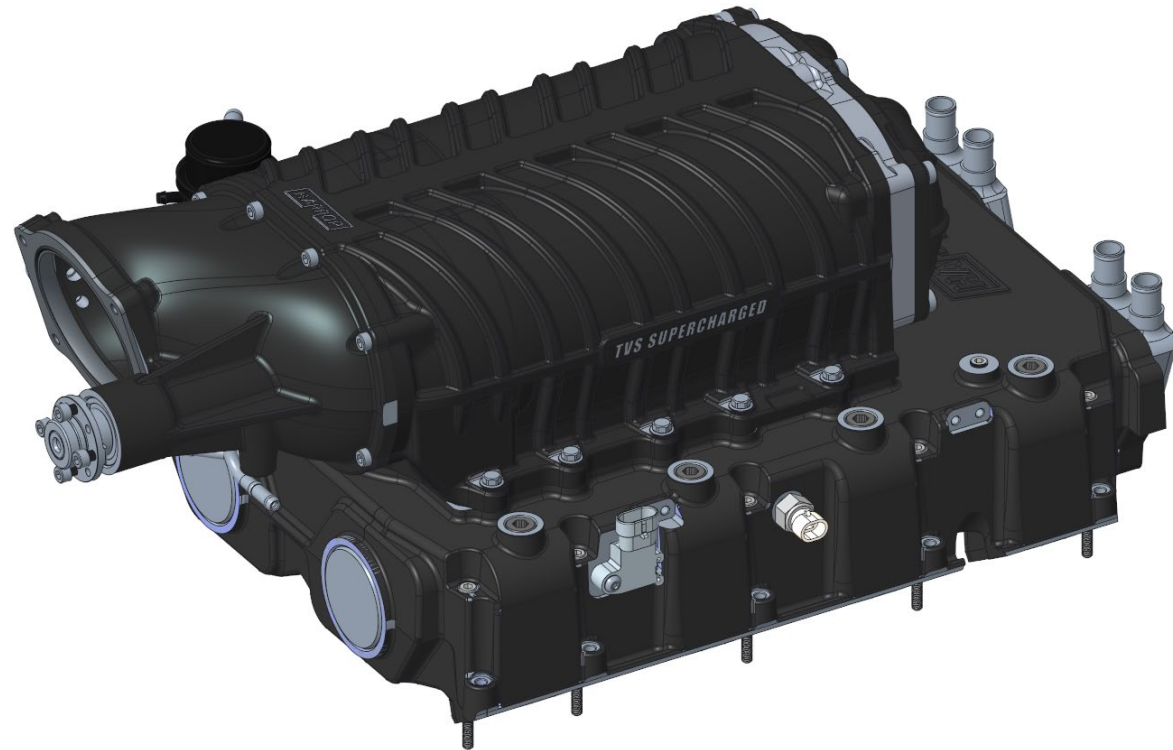

ENGINEERING PERFORMANCE SINCE 1955

25/11/2024

# Tech Guide

## LT TOP MOUNT TVS2650 SUPERCHARGER



### Intercooler layout and dimensions

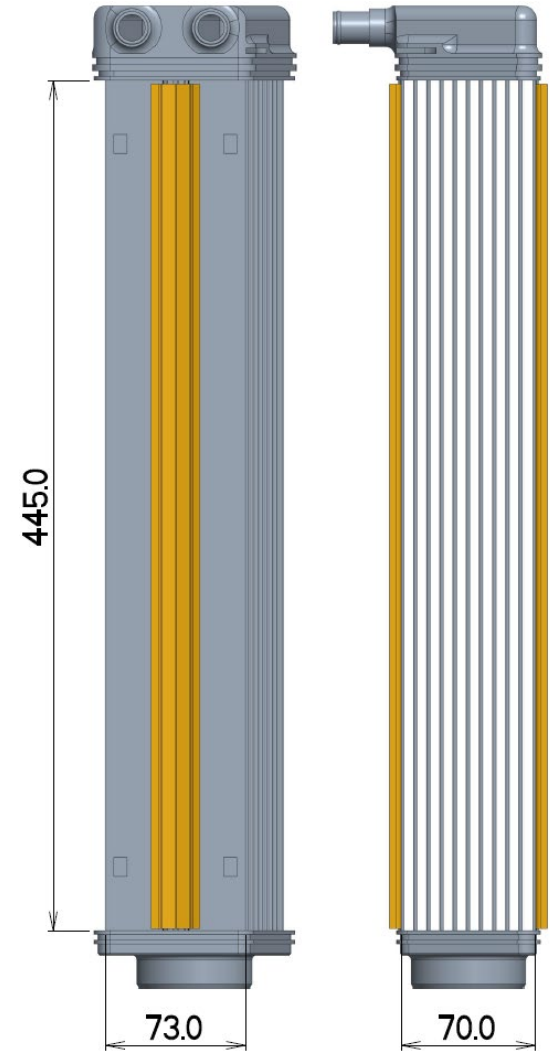
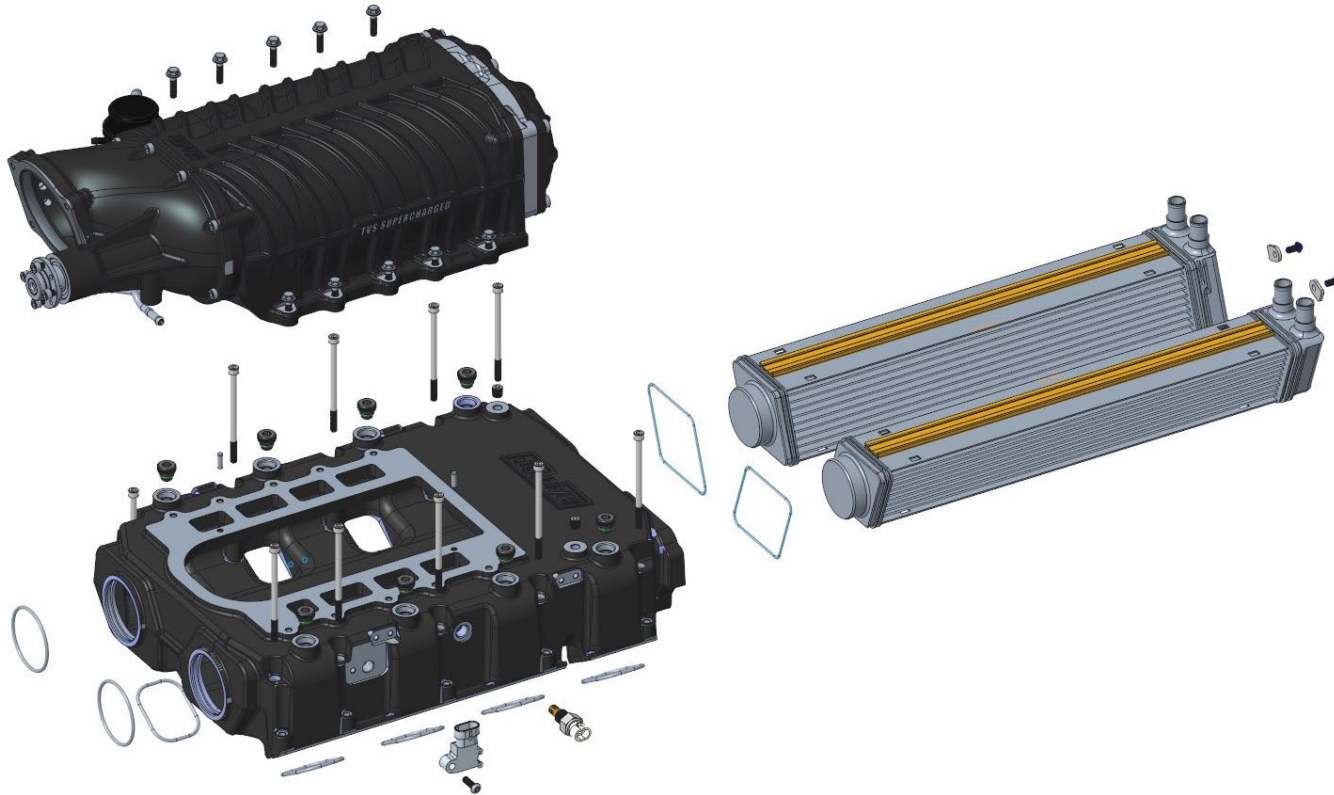

25/11/2024

ENGINEERING PERFORMANCE SINCE 1955

# Tech Guide

## LT TOP MOUNT TVS2650 SUPERCHARGER

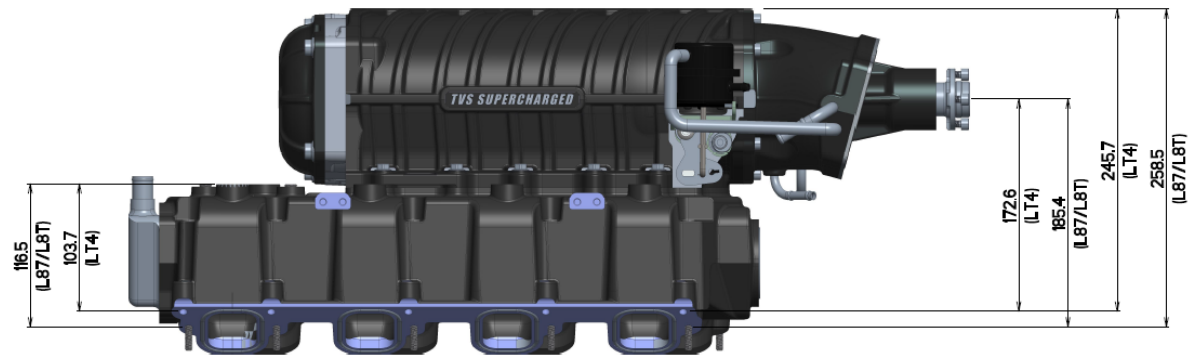
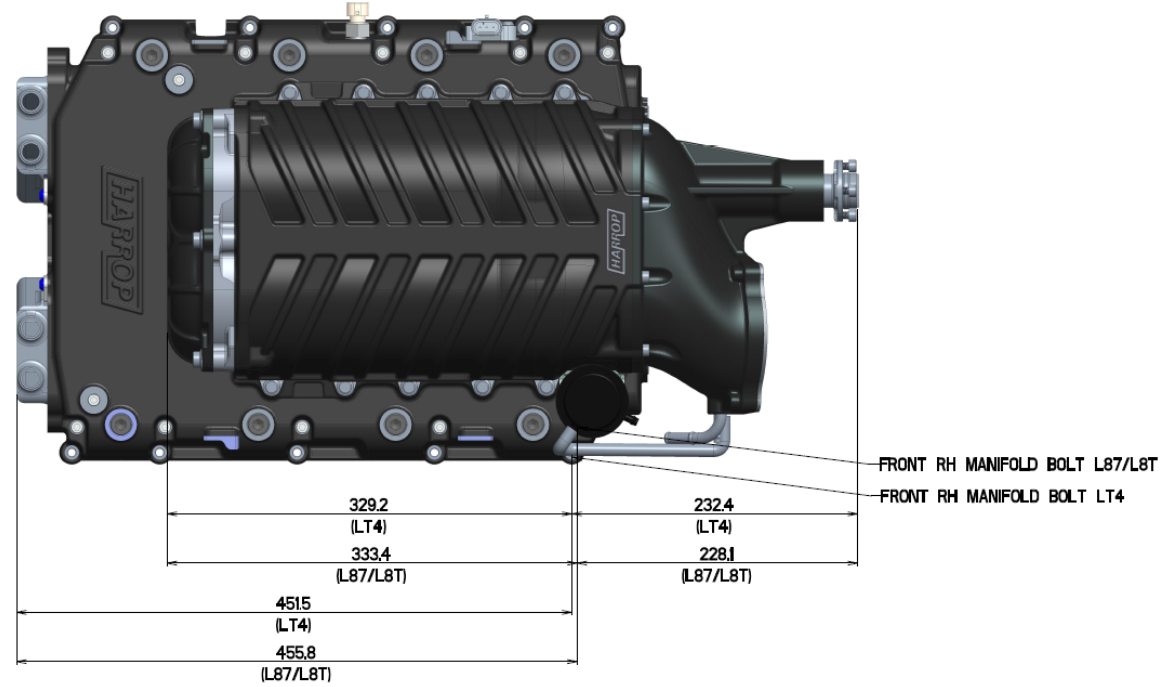

ENGINEERING PERFORMANCE SINCE 1955

25/11/2024

### Harrop LT Top Mount supercharger vs OEM LT4 Supercharger

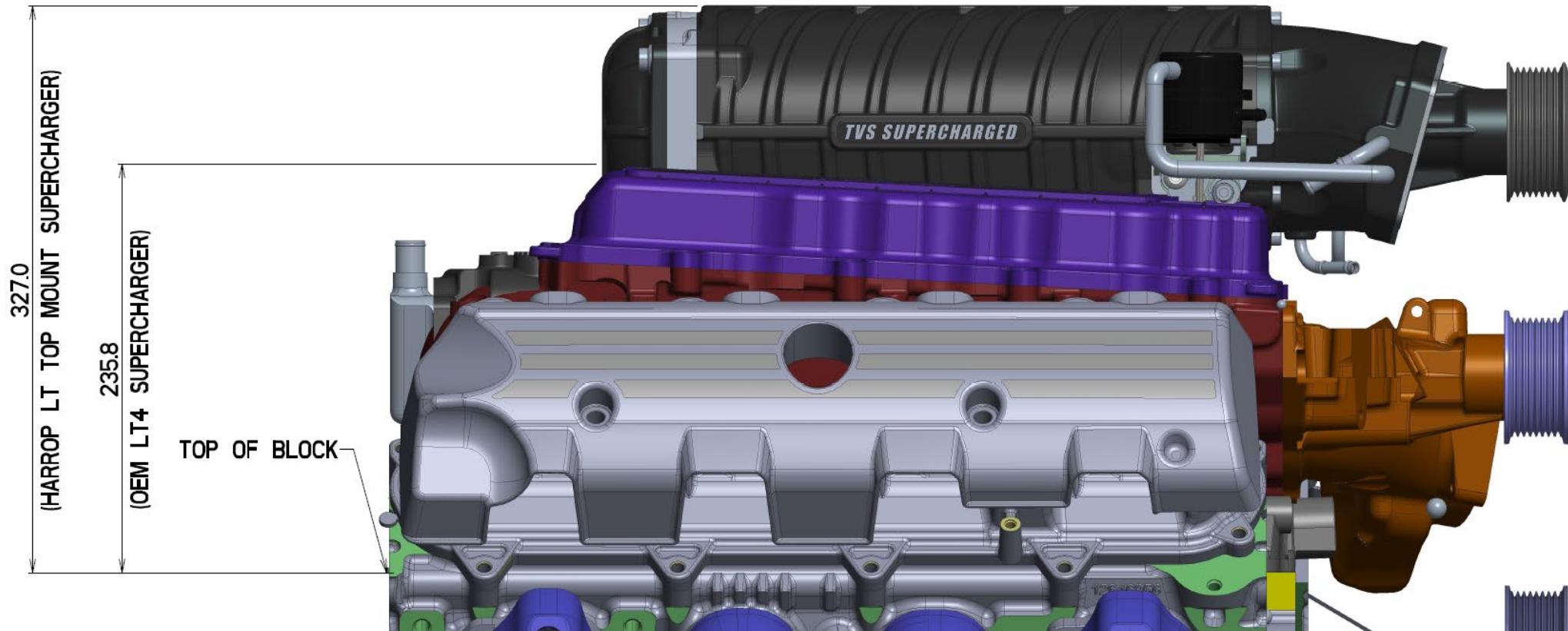

ENGINEERING PERFORMANCE SINCE 1955

25/11/2024

# Tech Guide

## LT TOP MOUNT TVS2650 SUPERCHARGER



### Harrop LT Top Mount Supercharger vs OEM L8T Intake Manifold

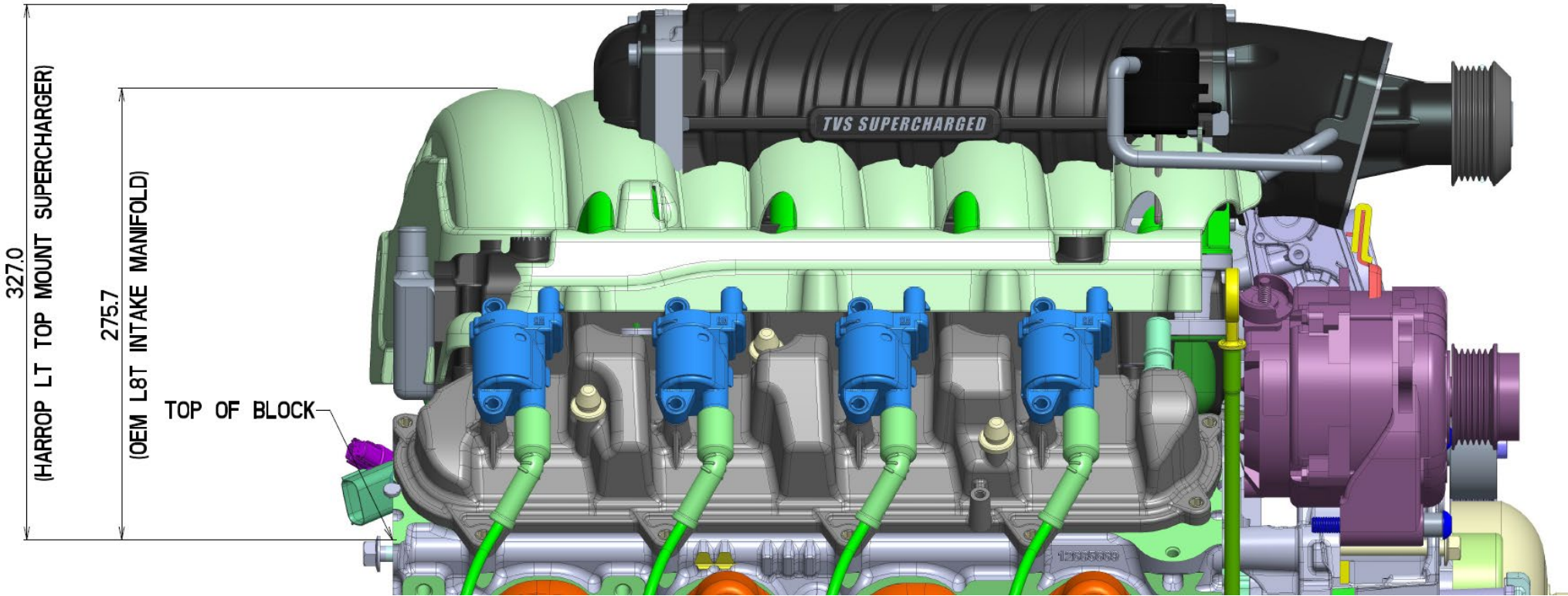

ENGINEERING PERFORMANCE SINCE 1955

25/11/2024

# Tech Guide

## LT TOP MOUNT TVS2650 SUPERCHARGER



### Port Injection Kit optional, P/N 99-AKIT16127

- Includes fuel rails, mounts and all required mounting hardware
- Can be used in conjunction with OEM DI fuel system
- -8 ORB both ends of rail for fuel line installation flexibility
- Suits Bosch EV14 compact injectors
- Replacement of DI injectors with solid injector plugs is required for port injection only applications

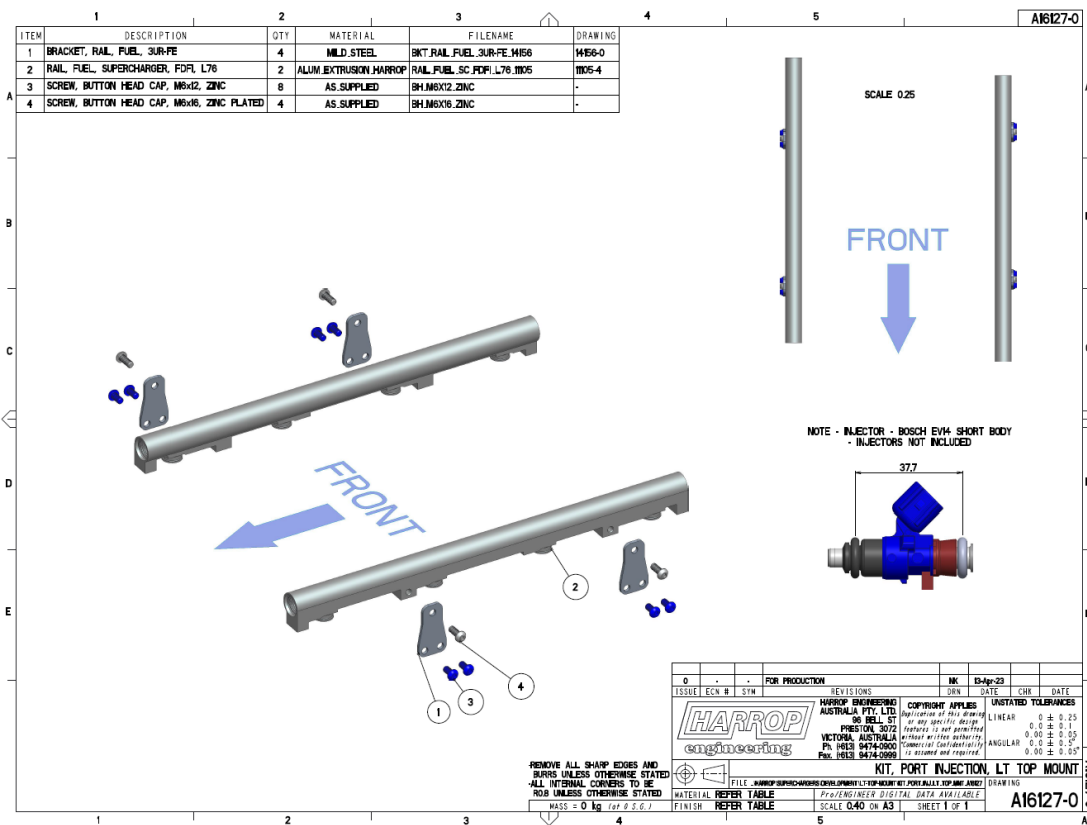
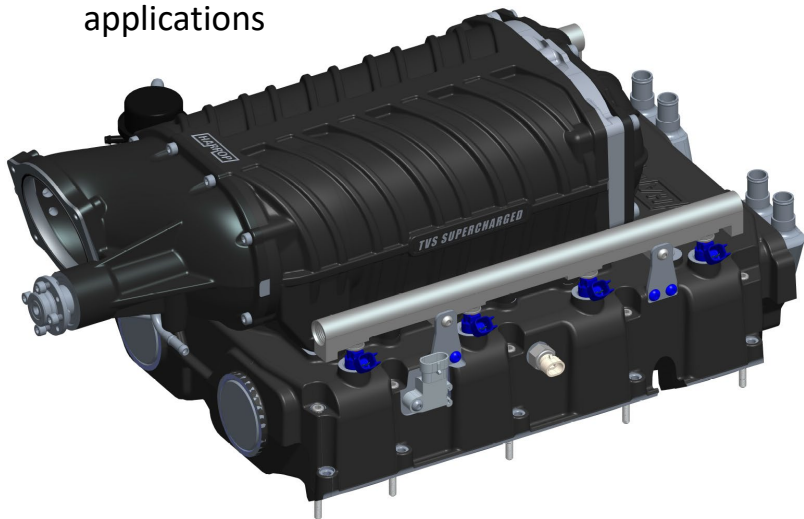

25/11/2024

ENGINEERING PERFORMANCE SINCE 1955

# Tech Guide

## LT TOP MOUNT TVS2650 SUPERCHARGER



### Supercharger Front Cover Options

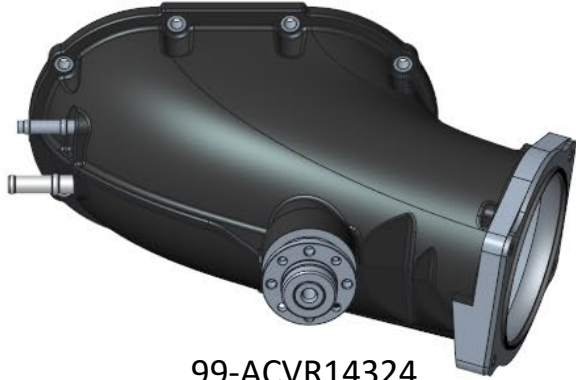

99-ACVR14324

LH facing to suit LS/LT 90 to 103mm TB



99-ACVR13167

Straight facing to suit LS/LT 90 to 103mm TB



99-ACVR14234

RH facing to suit LS/LT 90 to 92mm TB

99-ACVR13169

Integrated 110mm throttle electronic actuation

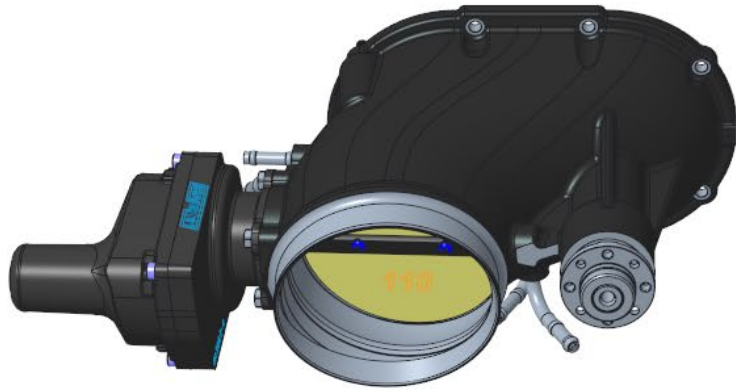

99-ACVR14983

Integrated 110mm throttle cable actuation

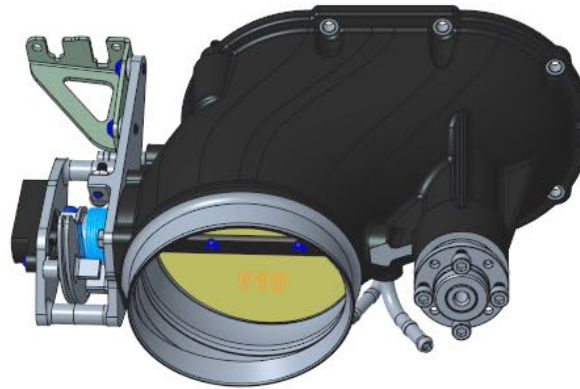

ENGINEERING PERFORMANCE SINCE 1955

25/11/2024



# Tech Guide

## LT TOP MOUNT TVS2650 SUPERCHARGER



### Belt Drive Configurations L83/L86

- Requires idler mount 99-ABKT14387.

Supercharger pulley	Belt
99-PLY16133 70mm	6PK2448
99-PLY16134 75mm	6PK2448
99-PLY16135 80mm	6PK2465
99-PLY16136 85mm	6PK2465
99-PLY16137 90mm	6PK2480

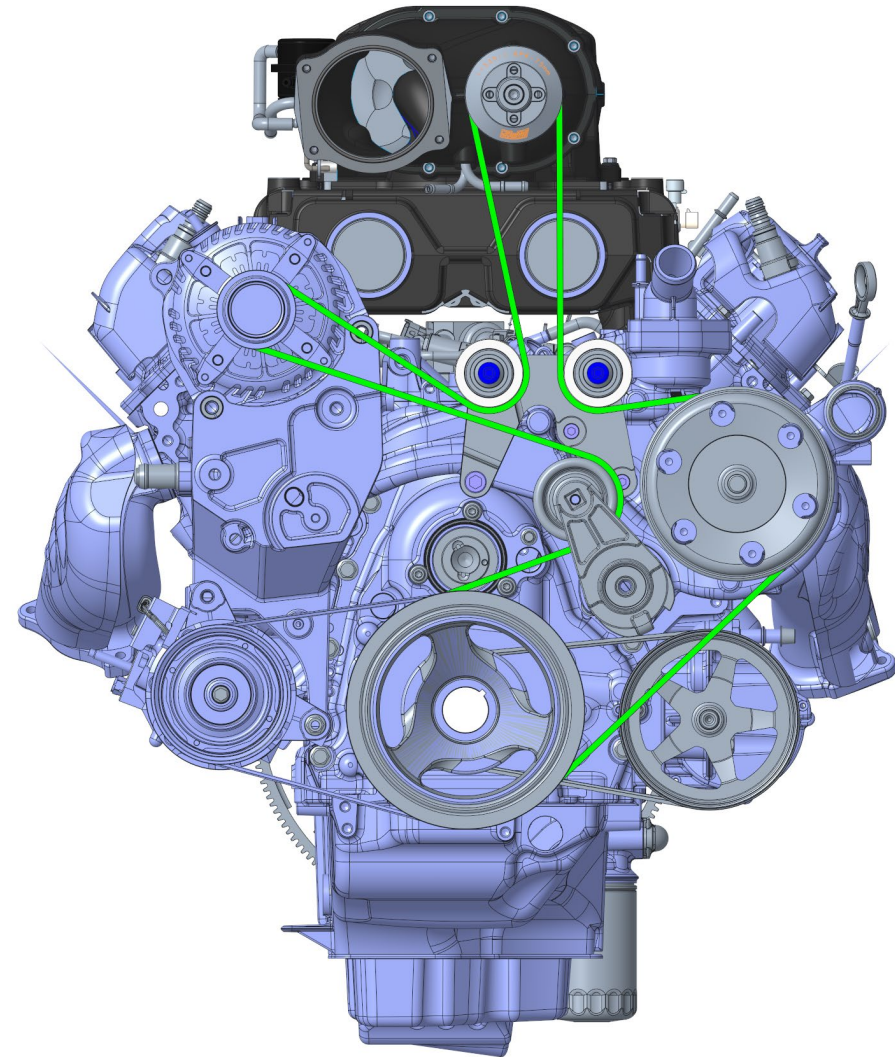

ENGINEERING PERFORMANCE SINCE 1955

25/11/2024

# Tech Guide

## LT TOP MOUNT TVS2650 SUPERCHARGER



### Belt Drive Configurations L84/L87

- Engine kit 99-EK-A16767 consisting of alternator relocation bracket, tensioner mount and additional idler mount required.

Supercharger pulley	Belt
99-PLY16128 70mm	6PK2405
99-PLY16129 75mm	6PK2405
99-PLY16130 80mm	6PK2415
99-PLY16131 85mm	6PK2430
99-PLY16132 90mm	6PK2430

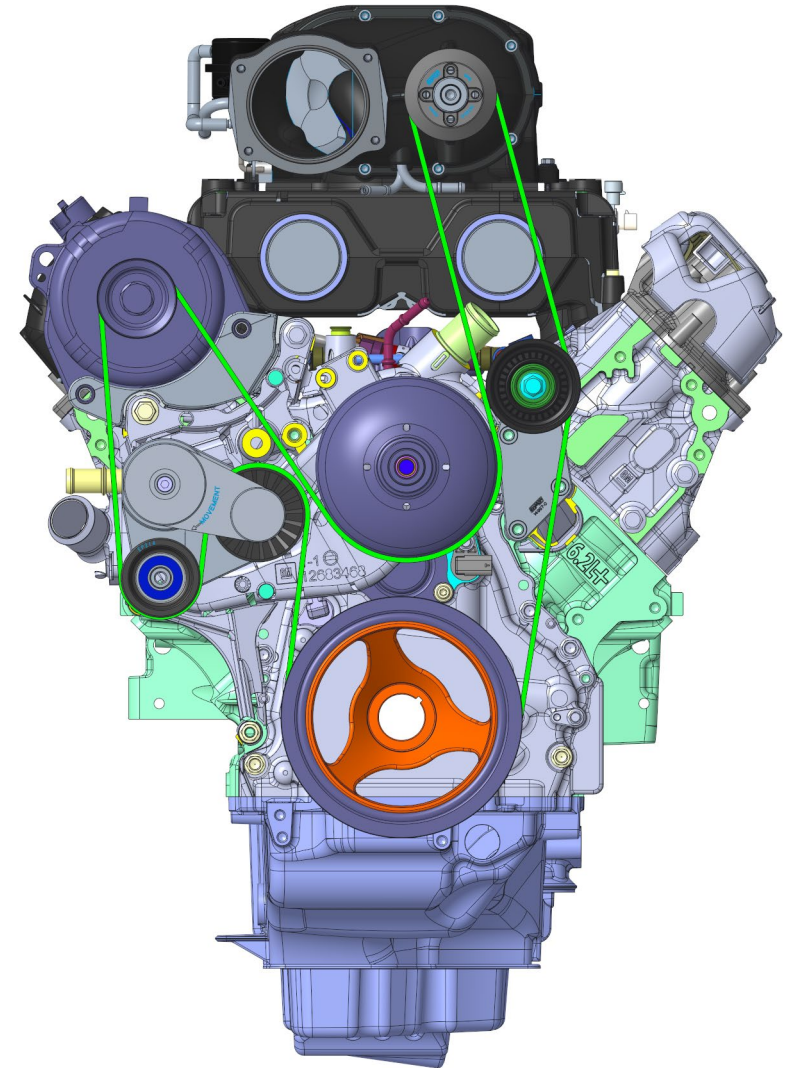

ENGINEERING PERFORMANCE SINCE 1955

25/11/2024

# Tech Guide

## LT TOP MOUNT TVS2650 SUPERCHARGER



### Belt Drive Configurations L8T 6PK

- To suit a 6PK belt drive, engine kit 99-EK-A16768 consisting of two additional idlers and their respective mounts is required (as shown on right).

Supercharger pulley	Belt
99-PLY16133 70mm	6PK2590
99-PLY16134 75mm	6PK2605
99-PLY16135 80mm	6PK2605
99-PLY16136 85mm	6PK2615
99-PLY16137 90mm	6PK2620

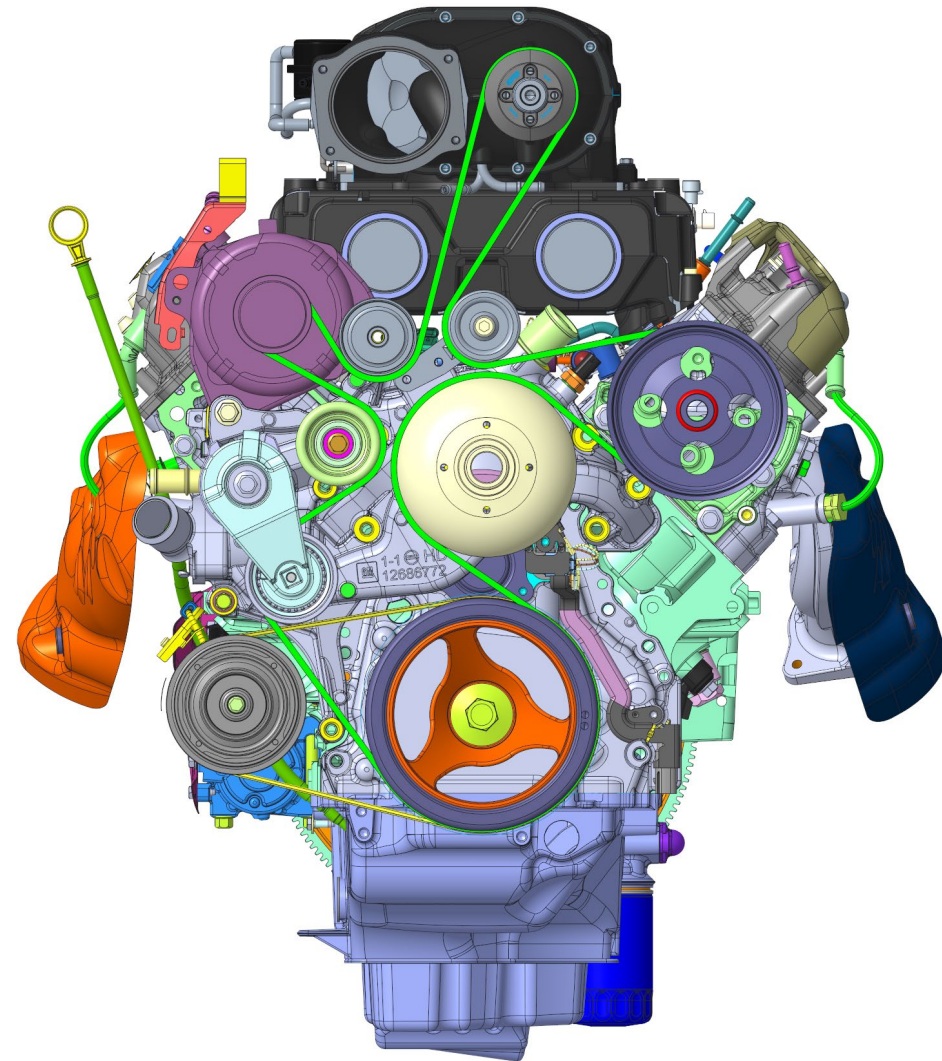

ENGINEERING PERFORMANCE SINCE 1955

25/11/2024

### Belt Drive Configurations L8T 8PK

- To suit an 8PK belt drive, engine kit 99-EK-A16769 consisting of 210mm 8PK crank pulley, alternator relocation bracket, tensioner, tensioner mount and additional idlers, is required. ATI 917306 balancer is also required.
- To upgrade from the 6PK belt drive setup to 8PK, 99-AKIT16796 is required which includes the above components. ATI 917306 balancer is also required.

Supercharger pulley	Belt
99-PLY16133 70mm	8PK2800HD
99-PLY16134 75mm	8PK2855HD
99-PLY16135 80mm	8PK2855HD
99-PLY16136 85mm	8PK2855HD
99-PLY16137 90mm	8PK2855HD

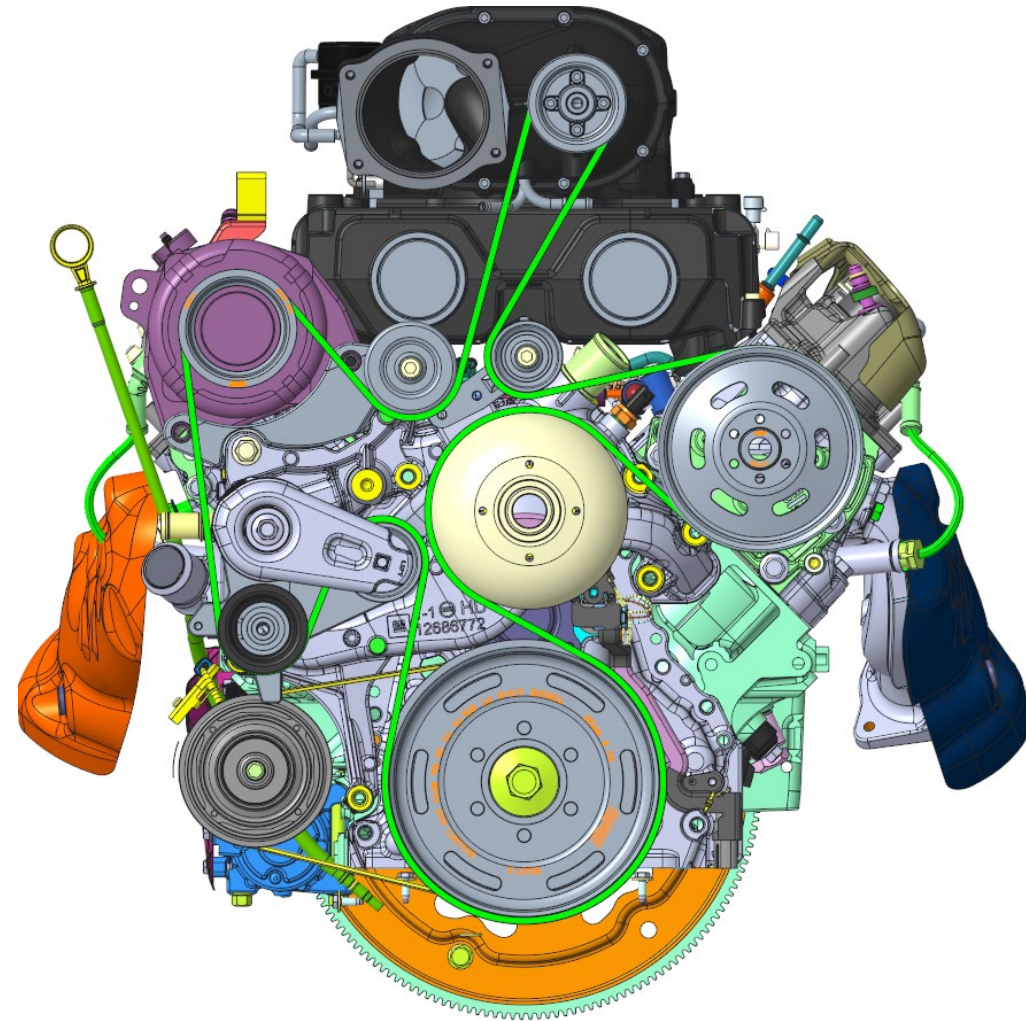

# Tech Guide

## LT TOP MOUNT TVS2650 SUPERCHARGER



### Belt Drive Configurations LT4

- Only suits wet sump LT4 belt drive setup

Supercharger pulley	Belt
99-PLY16762 70mm	8PK2414HD
99-PLY16763 75mm	8PK2414HD
99-PLY16764 80mm	8PK2430HD
99-PLY16765 85mm	8PK2430HD
99-PLY16766 90mm	8PK2440HD

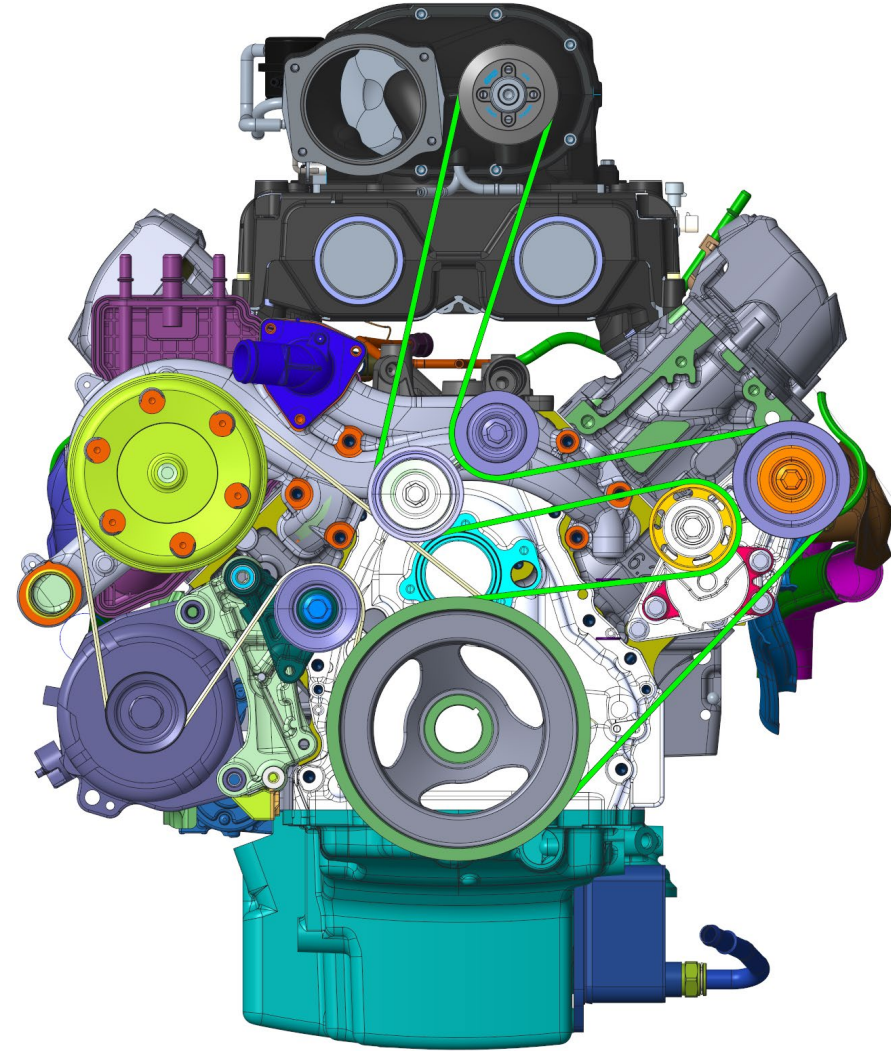

ENGINEERING PERFORMANCE SINCE 1955

25/11/2024

### Intercooler Routing

- Intercooler kit 99-AINT16795 is an optional kit that includes moulded hoses from the supercharger, 4 metres of 3/4" hose, reservoir bottle, a large 560x305x40mm radiator, electric coolant pump, wiring loom, hardware and mounts.
- Black arrow indicates flow direction.
- Intercooler reservoir must be mounted at the highest point in the circuit.
- Intercooler pump must be mounted below the bottom outlet of the reservoir.
- Intercooler system must be filled with a 1:1 mix of GM6277M coolant concentrate and distilled or deionised water.

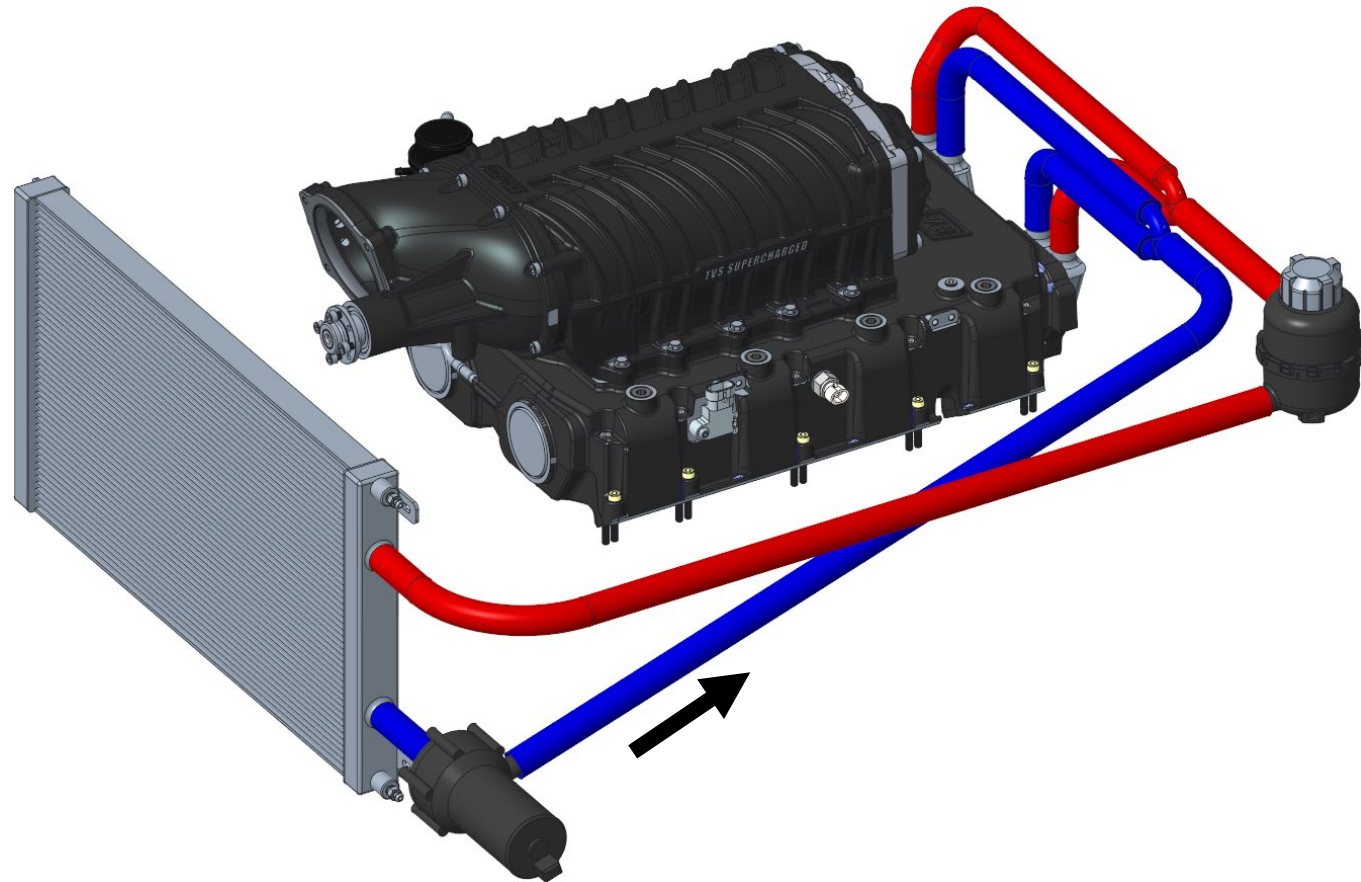

# Tech Guide

## LT TOP MOUNT TVS2650 SUPERCHARGER



### Performance Figures

ENGINE	COMPONENTS	POWER CORRECTION	POWER	TORQUE	BOOST	PULLEY RATIO	FUEL
6.6L L8T	Factory engine	SAE J1349 2004	401 hp @ 5200 RPM	464 lb ft @ 4000 RPM	N/A	N/A	91 RON
6.6L L8T and Harrop LT Top Mount TVS 2650 Supercharger	Forged Rods and Piston 11:1 CR Factory Heads Ported BTR Gen V Stage 2 PD Cam	SAE J1349 2004	867 hp @ 6300 RPM	756 lb ft @ 5500 RPM	11 PSI	80mm SC pulley 187mm crank pulley 2.34:1 6PK Drive	98 RON
6.6L L8T and Harrop LT Top Mount TVS 2650 Supercharger	Forged Rods and Piston 11:1 CR Factory Heads Ported BTR Gen V Stage 2 PD Cam	SAE J1349 2004	939 hp @ 6300 RPM	788 lb ft @ 5900 RPM	11 PSI	80mm SC pulley 187mm crank pulley 2.34:1 6PK Drive	E85
6.6L L8T and Harrop LT Top Mount TVS 2650 Supercharger	Forged Rods and Piston 11:1 CR Factory Heads Ported BTR Gen V Stage 2 PD Cam	SAE J1349 2004	1006 hp @ 7000 RPM	803 lb ft @ 6000 RPM	12.5 PSI	85mm SC pulley 205mm crank pulley 2.41:1 8PK Drive	E85
6.6L L8T and Harrop LT Top Mount TVS 2650 Supercharger	Forged Rods and Piston 11:1 CR Factory Heads Ported BTR Gen V Stage 2 PD Cam	SAE J1349 2004	1047 hp @ 7000 RPM	844 lb ft @ 5900 RPM	14.5 PSI	80mm SC pulley 205mm crank pulley 2.56:1 8PK Drive	E85
6.6L L8T and Harrop LT Top Mount TVS 2650 Supercharger	Forged Rods and Piston 11:1 CR Factory Heads Ported BTR Gen V Stage 2 PD Cam	SAE J1349 2004	1078 hp @ 7000 RPM	876 lb ft @ 6000 RPM	16.2 PSI	75mm SC pulley 205mm crank pulley 2.73:1 8PK Drive	E85

Power figures measured at flywheel on engine dyno. Visit HarropTV to see the LT top mount supercharger in action <https://youtu.be/mi3lPAC0Eig>

ENGINEERING PERFORMANCE SINCE 1955

25/11/2024